



Alfa Laval MultiJet 25

Rotary jet head for high-impact tank cleaning for industrial application

Introduction

The Alfa Laval MultiJet 25 is a rotary jet head tank cleaning machine for use in industrial environments. Built to clean tanks with capacities from 15 and 150 m³, it combines pressure and flow to create high-impact cleaning jets rotate in a repeatable and reliable 360-degree cleaning pattern.

The MultiJet 25 minimizes the consumption of water and cleaning media. Easy to customize to meet customer requirements, it allows companies to spend less time cleaning and more time producing.

Application

The Alfa Laval MultiJet 25 is designed for the removal of the toughest residues from industrial tanks across a broad range of industries, such as the home care, chemical, pulp and paper, ethanol, starch, and oil industries.

Benefits

- 60% faster cleaning = more time for production
- Saves up to 70% of your cleaning cost
- Eliminates the need for confined space entry for manual tank cleaning
- High-impact cleaning in a 360° repeatable cleaning pattern
- Cleaning process can be validated using Alfa Laval Rotacheck

Standard Design

The choice of nozzle diameters can optimize jet impact length and flow rate at the desired pressure. A 2.1 material certificate and an ATEX certification are available.

Alfa Laval offers a wide range of tank cleaning machines suitable for different duties and industries. An alternative that offers performance similar to the Alfa Laval MultiJet 25 is the Alfa Laval GJ PF, which is ideal applications that require a small tank inlet opening.

Working principle

The high-impact jet stream from the Alfa Laval MultiJet rotary jet head covers the entire surface of the tank interior in a successively denser pattern. This achieves a powerful mechanical impact with a low volume of water and cleaning media.

The flow of the cleaning fluid makes the nozzles perform a geared rotation around the vertical and horizontal axes. In the first cycle, the nozzles lay out a course pattern on the tank surface.



The subsequent cycles gradually make the pattern denser until at full cleaning pattern is reached. Once the full cleaning pattern is reached, the machine will start over again and continue to perform the next full cleaning pattern.

Certificates

2.1 material certificate and ATEX.



TECHNICAL DATA

Lubricant:	Self-lubricating with the cleaning fluid
Max throw length:	9 - 14 m
Impact throw length:	4 - 8 m
Pressure	
Working pressure:	3 - 8 bar
Recommended pressure:	5 - 6.5 bar

Cleaning Pattern

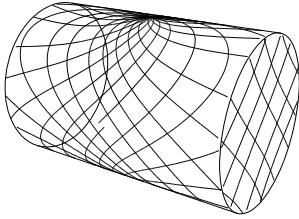

First cycle

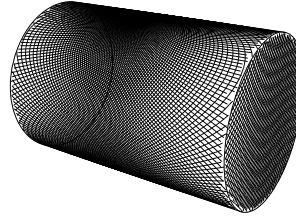

Full pattern

The above drawings show the cleaning pattern achieved on a cylindrical horizontal vessel. The difference between the first cycle and the full pattern represents the number of additional cycles available to increase the density of the cleaning.

PHYSICAL DATA

Materials	
316L (UNS S31603), Duplex steel (UNS N31803), Duplex steel (UNS S 21800), EPDM*, PEEK*, PVDF*, PFA*	
* FDA compliance 21CFR§177	
Surface finish:	
	Exterior finish: Glass blasted
Temperature	
Max. working temperature:	95°C
Max. ambient temperature:	140°C
Weight:	
	5.1 kg.
Connections	
Standard female thread:	1" Rp (BSP) or NPT

Caution

Avoid hydraulic shock, hard and abrasive particles in the cleaning liquid, as this can cause increased wear and/or damage of internal mechanisms. In general, a filter in the supply line is recommended. Do not use for gas evacuation or air dispersion. For steaming we refer to the manual.

Flow Rate

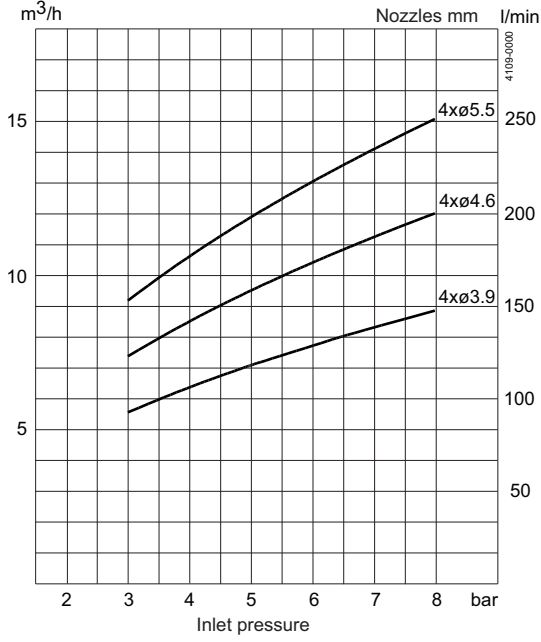

Impact Throw Length

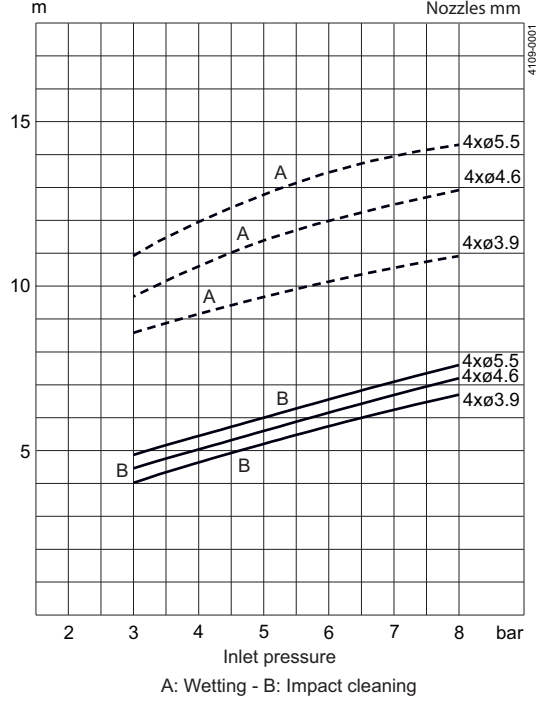

Cleaning Time, Complete Pattern

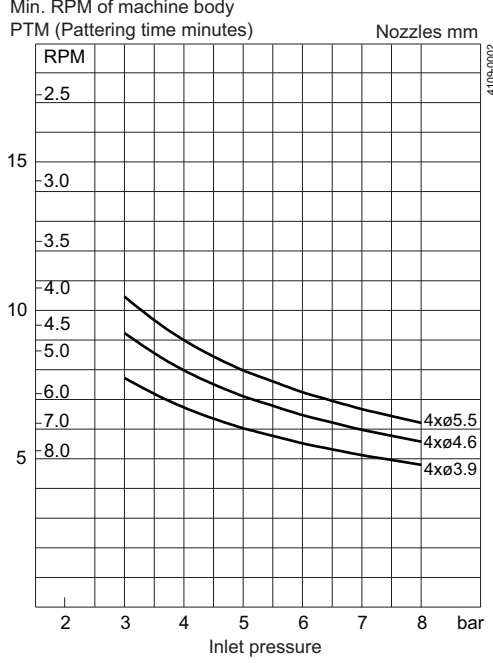

Dimensions

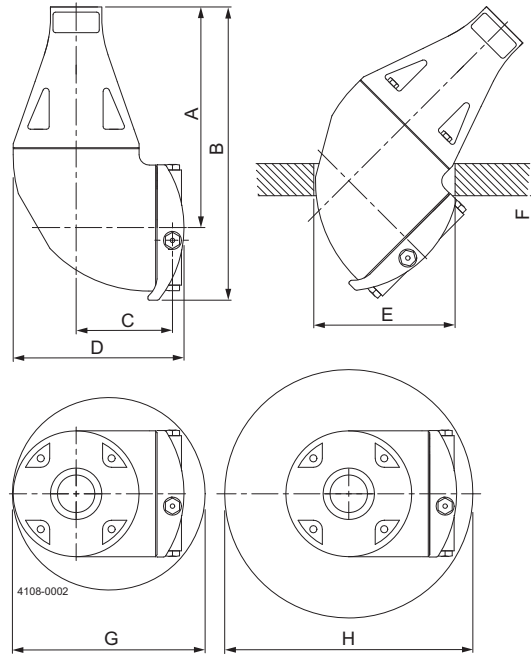

	A	B	C	D	E	F	G	H
mm	173	230	75	133	ø110	max. 25	ø150	ø200

TRAX simulation tool

TRAX is a unique software that simulates how the Toftejorg MultiJet 25 performs in a specific tank or vessel. The simulation gives information on wetting intensity, pattern mesh width and cleaning jet velocity. This information is used to determine the best location of the tank cleaning machine and the correct combination of flow, time and pressure to implement.

A TRAX demo containing different cleaning simulations covering a variety of applications can be used as reference and documentation for tank cleaning applications. A TRAX simulation is free and available upon request.

Wetting Intensity

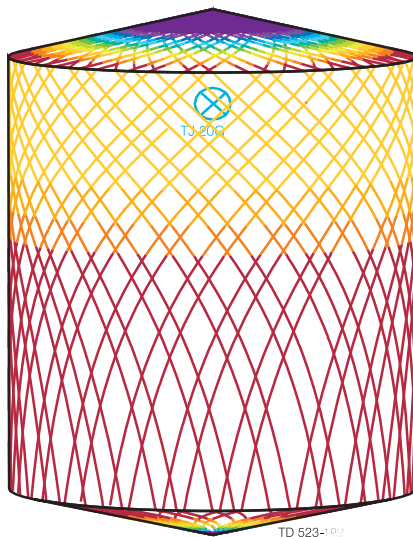
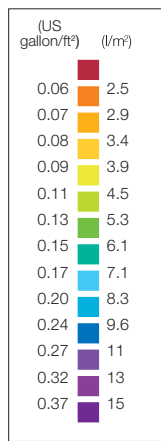

D4.6m H5.5m, Toftejorg MultiJet 25. 4 x ø5.5 mm, Time = 2.08 min., Water consumption = 403 l

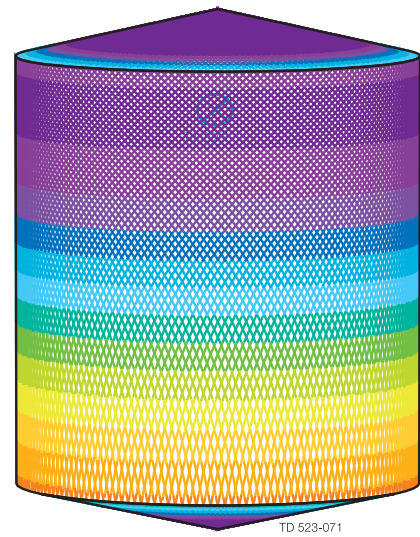

D4.6m H5.5m, Toftejorg MultiJet 25. 4 x ø5.5 mm, Time = 8.3 min., Water consumption = 1612 l

Alfa Laval reserves the right to change specifications without prior notification.

How to contact Alfa Laval

Contact details for all countries are continually updated on our website. Please visit www.alfalaval.com to access the information direct.