



Alfa Laval RJ Mixer IM-15

Rotary Jet Mixer

Introduction

The Alfa Laval IM 15 Rotary Jet Mixer effectively handles liquid mixing, gas dispersion, powder mixing, and tank cleaning while reducing mixing time, energy consumption and costs.

Patented technology based on proven Rotary jet Head technology, it provides quick, efficient and uniform mixing without any batch rotation or the use of baffles. It also ensures greater process flexibility, making it easy to switch to new product formulations with diverse viscosities, densities and volumes.

Applications

The IM 15 Rotary Jet Mixer is designed for liquid mixing, gas dispersion (aeration, deaeration, carbonation), and powder mixing in process and storage vessels from 2 to 100 m³ in size across the dairy, food, beverage, brewery, healthcare, home and personal care, and biotechnology industries.

When the tank is empty, the IM 15 also acts as a superb Cleaning-in-Place (CIP) system, saving water, cleaning media and energy compared to using a spray ball CIP system.

Benefits

- Fast, effective liquid mixing performance in tanks
- Efficient gas and powder dispersion
- Can be used as tank cleaning machine
- Handles multiple applications
- Unmatched, cost-effective mixing performance
- Simplified, hygienic design, modest investment
- Optional pre-engineered skid-mounted pump unit available

Standard design

The Alfa Laval IM 15 Rotary Jet Mixer consists of a mixer body, turbine and nozzles. Compared to traditional systems using propeller mixers, there is no need for a shaft, seal or gearbox. Excellent mixing is achieved without the use of baffles or any batch rotation. Available in four different models (IM 10, IM 15, IM 20, IM 25), these mixers are designed for tank volumes from 100 litres in size and beyond, and they are capable of handling re-circulation flow rates up to 90 m³/h.



Working principle

Before round pumping or adding any products from upstream pipe works, ensure that the IM 15 Rotary Jet Mixer is positioned at the correct level and submerged into the liquid. Two or four nozzles feed the liquid, gas or powder into the liquid in the tank. The nozzles rotate around both the horizontal and vertical axes in a 360° movement. This three-dimensional jet rotation enables the jets to reach the entire tank volume, providing fast, efficient mixing of the injected liquid, gas or powder without requiring batch rotation.

The complete system is built with a circulation loop, enabling liquid to be pumped from the bottom of the tank and back into the Rotary Jet Mixer. For faster mixing requirements, several rotary jet mixers can be installed in series.



TECHNICAL DATA

Lubricant:	Self-lubricating with the mixing/cleaning fluid
Connection:	Standard thread 1.5" BSP or NPT, female
Min. tank opening:	See dimension drawings

Pressure

Working pressure:	2-12 bar
Recommended pressure during mixing:	2-6 bar
Recommended pressure during CIP:	5-6.5 bar

PHYSICAL DATA

Materials

Materials:	AISI 316L, AISI 316, SAF 2205, PTFE, PEEK, Tefzel, Ceramics
------------	---

Weight

Weight:	6.1 kg.
---------	---------

Temperature

Max. working temperature:	95°C
Max. ambient temperature:	140°C

Flow rate

Relationship between inlet pressure and flow rate for liquids with waterlike properties for the IM 15 Rotary Jet Mixer.

Volumetric flow rate [m³/h]

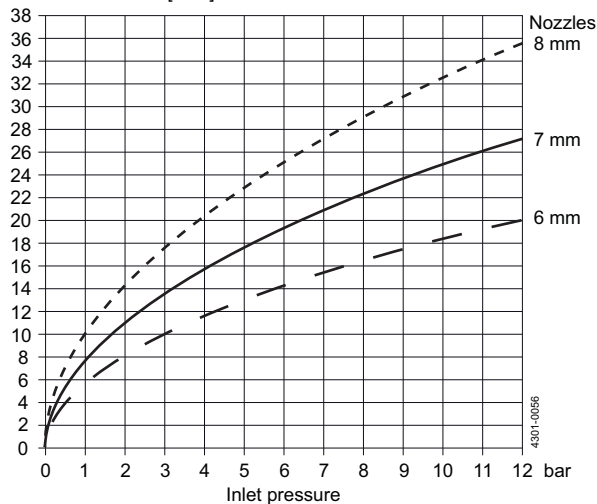

Reach of jet

Reach of jet for the IM 15 during cleaning, and indicative reach of jet for mixing of liquids with water-like properties.

Reach of jet [m]

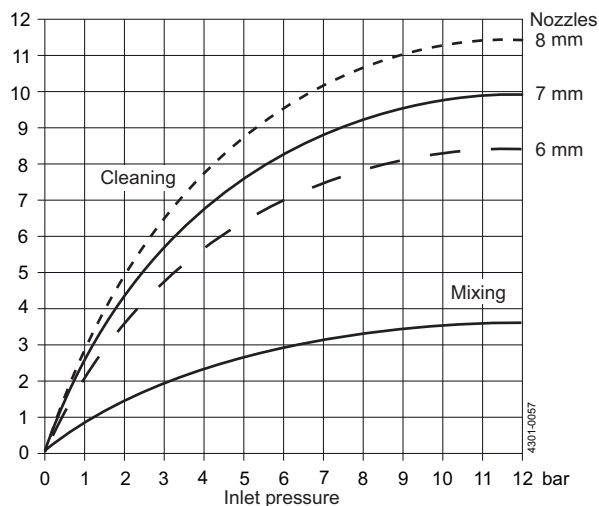

Dimensions (mm)

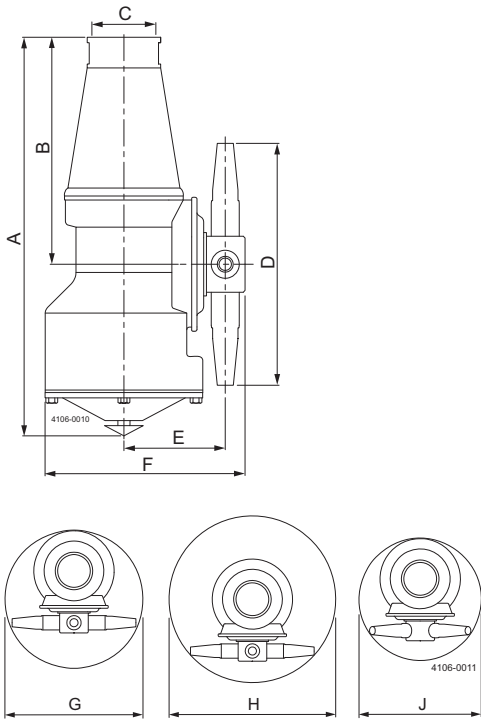

A	B	C	D	E	F	G	H	J
297	170	50	204	78	152	ø216	ø264	ø180

The Rotary Jet Mixing technology

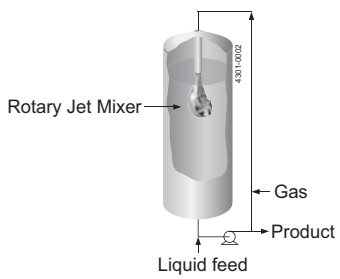

Traditional Mixing technology

Round pumping

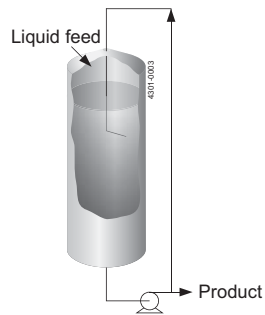

Propeller mixing

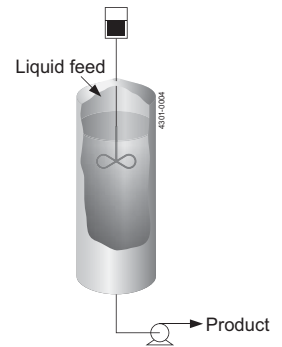

Alfa Laval reserves the right to change specifications without prior notification.

How to contact Alfa Laval

Contact details for all countries
are continually updated on our website.
Please visit www.alfalaval.com to
access the information direct.