



Alfa Laval SaniJet 25

Rotary jet head for high-impact tank cleaning for hygienic application

Introduction

The Alfa Laval SaniJet 25 is a rotary jet head tank cleaning machine for hygienic environments. Built to clean tanks with capacities from 15 and 150 m³ it combines pressure and flow to create high-impact cleaning jets that rotate in a repeatable and reliable 360-degree cleaning pattern.

The SaniJet 25 minimizes the consumption of water and cleaning media. Easy to customize to meet customer requirements, it allows companies to spend less time cleaning and more time producing.

Application

The Alfa Laval SaniJet 25 is designed for the removal of the toughest residues from hygienic tanks across a broad range of industries, such as the dairy, brewery, food and beverage industries.

Benefits

- 60% faster cleaning = more time for production
- Saves up to 70% of your cleaning cost
- Eliminates the need for confined space entry for manual tank cleaning
- High-impact cleaning in a 360° repeatable cleaning pattern
- Cleaning process can be validated using Alfa Laval Rotacheck

Standard Design

The choice of nozzle diameters can optimize jet impact length and flow rate at the desired pressure.

Alfa Laval offers a wide range of tank cleaning machines suitable for different duties and industries. An alternative that offers performance similar to the Alfa Laval SaniJet 25 is the Alfa Laval SaniJet 25 UltraPure for hygienic applications that require full traceability of product-wetted parts and smooth qualification and validation processes through the Alfa Laval Q-doc documentation package.

Working principle

The high-impact jet stream from the Alfa Laval SaniJet 25 rotary jet head is designed to cover the entire surface of the tank interior in a successively denser pattern. This achieves a powerful mechanical impact with a low volume of water and cleaning media.

The flow of the cleaning fluid makes the nozzles perform a geared rotation around the vertical and horizontal axes. In the first cycle, the nozzles lay out a course pattern on the tank surface.



The subsequent cycles gradually make the pattern denser until at full cleaning pattern is reached. Once the full cleaning pattern is reached, the machine will start over again and continue to perform the next full cleaning pattern.

Certificates

2.2 material certificate, Q-doc, ATEX.



TECHNICAL DATA

Lubricant:	Self-lubricating with the cleaning fluid
Standard Surface finish:	Ra 0.5µm exterior / Ra 0.8µm internal
Max throw length:	12.5- 17 m
Impact throw length:	5.5- 10m

Pressure

Working pressure:	3 - 8 bar
Recommended pressure:	5 - 6.5 bar

Cleaning Pattern

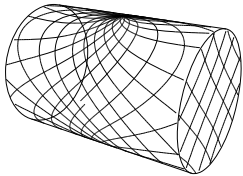

First cycle

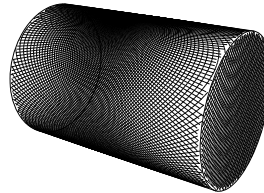

Full pattern

The above drawings show the cleaning pattern achieved on a cylindrical horizontal vessel. The difference between the first cycle and the full pattern represents the number of additional cycles available to increase the density of the cleaning.

PHYSICAL DATA

Materials

316L (UNS S31603), Duplex steel (UNS N31803), Duplex steel (UNS S21800), PEEK*, PFA* and EPDM*

* FDA compliance 21CFR§177

Welding connection

1" ISO, 1" ANSI/Sch40, 1½" BPE US/SWG, 1½"Dairy, 1½"ANSI/Sch40 or NW40.

Temperature

Max. working temperature:	95°C
Max. ambient temperature:	140°C

Weight:	6.3 kg.
---------	---------

Caution

Avoid hydraulic shock, hard and abrasive particles in the cleaning liquid, as this can cause increased wear and/or damage of internal mechanisms. In general, a filter in the supply line is recommended. Do not use for gas evacuation or air dispersion. For steaming we refer to the manual.

Qualification Documentation (Q-doc)

Documentation specification

	Equipment Documentation includes:
Q-doc	<ul style="list-style-type: none"> - EN 10204 type 3.1 Material Inspection certificate - FDA Declaration of Conformity - ADI Declaration (TSE) - QC Declaration of Conformity
ATEX	<p>ATEX approved machine for use in explosive atmospheres.</p> <p>Category 1 for installation in zone 0/20 in accordance to Ex II 1 GD c T 140°C.</p>

Flow Rate

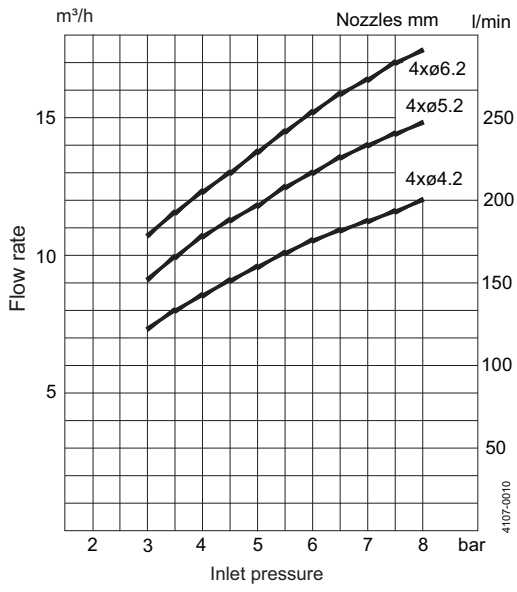

Impact Throw Length

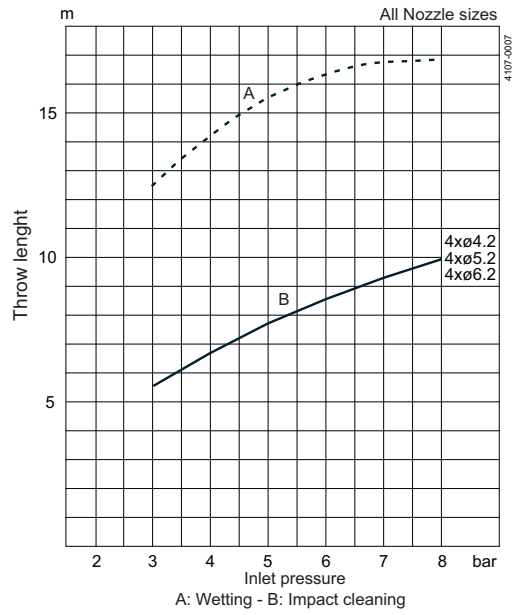

Cleaning Time, Complete Pattern

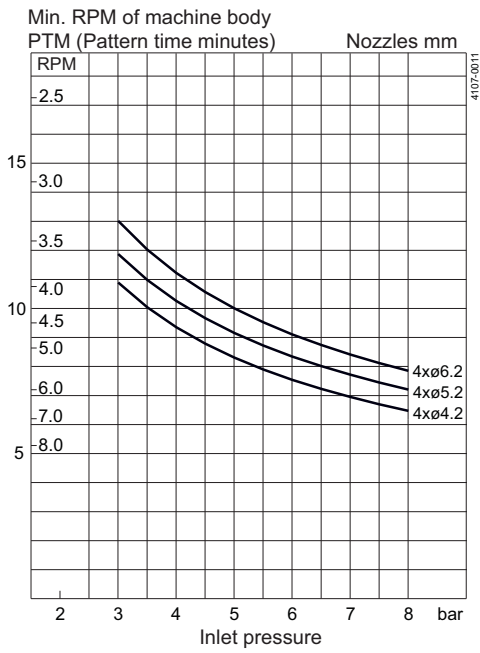

Dimensions

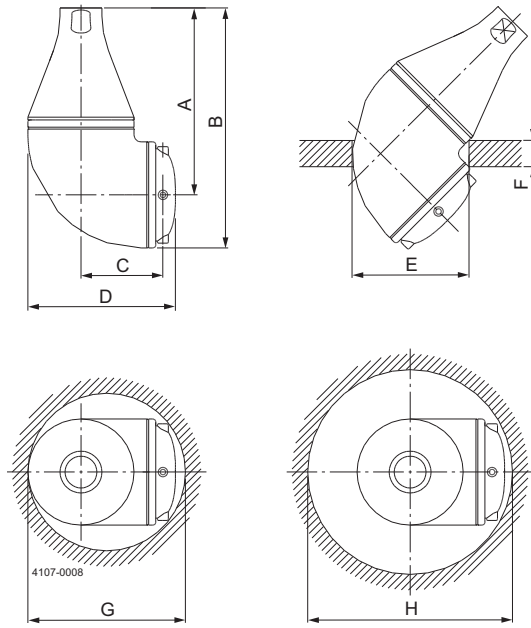

	A	B	C	D	E	F	G	H
mm	178	228.5	80	140	ø110	max. 25	ø150	ø195

Alfa Laval reserves the right to change specifications without prior notification.

How to contact Alfa Laval
 Contact details for all countries
 are continually updated on our website.
 Please visit www.alfalaval.com to
 access the information direct.