



Alfa Laval SB Anti Vacuum House

Safety valves

Introduction

The Alfa Laval SB Anti Vacuum House is a safety valve housing that minimizes the risk of implosion in closed process tanks or vessels that are subject to vacuum conditions while emptying the tank, cool rinsing after hot-cleaning, or caustic cleaning in a CO₂ atmosphere. It helps protect tanks from vacuum conditions that may cause tank implosion, damage or deformation. It can be combined with safety valves or pressure regulators mounted at the tank top. This is a cost-efficient, reliable and easy to install, it provides effective vacuum protection, while boosting process reliability, equipment and personnel safety.

Application

This anti-vacuum valve housing is designed for use in hygienic process tanks in the brewery, dairy, food, beverage and many other industries

Benefits

- Minimal risk of tank collapse due to internal vacuum conditions
- Fully cleanable via built-in Cleaning-in-Place nozzle
- Easy to integrate
- Low investment due to simplified installation
- Can be combined with other valves in a customized tank top

Standard design

The Alfa Laval Anti Vacuum House consists of an AISI 316L stainless steel housing, a vacuum tail and an EPDM seal. PED 97/23/EU-compliant, it can be used as an integral part of a SCANDI BREW® tank top system.

Working principle

The Alfa Laval Anti Vacuum House operates at a pressure of 50 mmH₂O / 5 mbar for all valve sizes to protect against implosion. When combined with a safety valve, it also helps protect the tank from overpressure and ensures discharge if pressure in the tank exceeds the pre-set opening value. When combined with regulating valves, it helps ensure pressure relief if pressure in the tank exceeds the pre-set opening value.



TECHNICAL DATA

Nominal size	Opening pressure (ΔP)	Allowable pressure PS
2"	50 mmH ₂ O	4.5 bar
3"	50 mmH ₂ O	4.5 bar
4"	50 mmH ₂ O	4.5 bar
6"	50 mmH ₂ O	4.5 bar

PHYSICAL DATA

Materials	
Product wetted steel parts:	EN 1.4404 (AISI 316L)
Product wetted seals:	EPDM

Connections

Nut and liner acc. DIN 11851

Clamp ferrule ISO 2852

Nut and liner acc. SMS Swedish Standard Union

Weld End acc. DIN 11850 or ISO 2037 depending on valve size

Options

The Anti Vacuum House provides vacuum protection and can be combined with other valves to provide following functions:

- Safety valves for tank overpressure protection
- Regulating valves for process protection

Available combinations

Anti Vacuum House	Regulating Valve		Safety Valve
Nominal size	CO ₂ House	Pressure Exhaust	Pressure Relief Valve
2"	X	X	
3"	X	X	X
4"	X	X	X
6"	X	X	X

Anti Vacuum House with CO₂ House

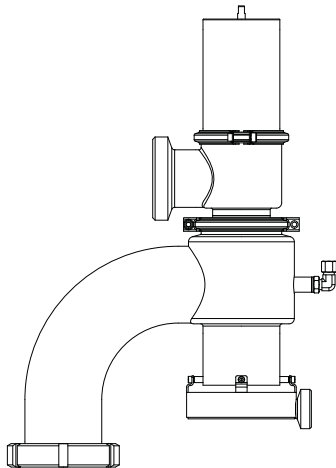

Anti Vacuum House with Pressure Exhaust

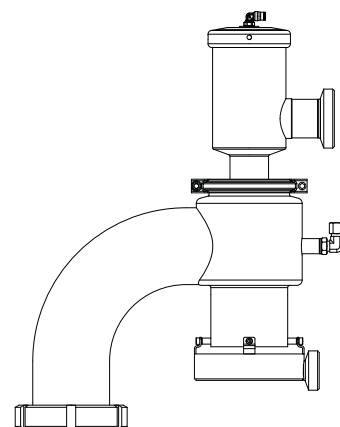

Anti Vacuum House with Pressure Relief Valve

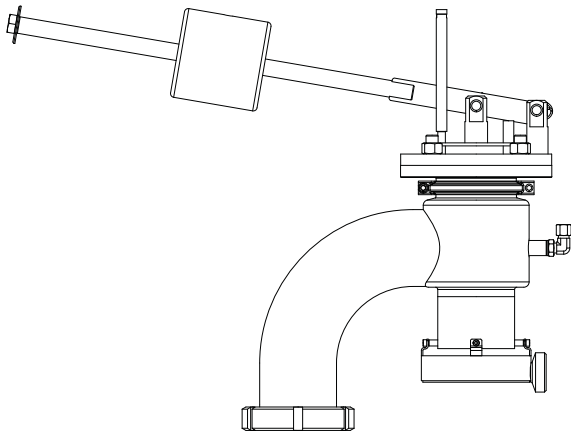

Cross section of Anti Vacuum House with Force opener, Proximity sensor and Drain collector

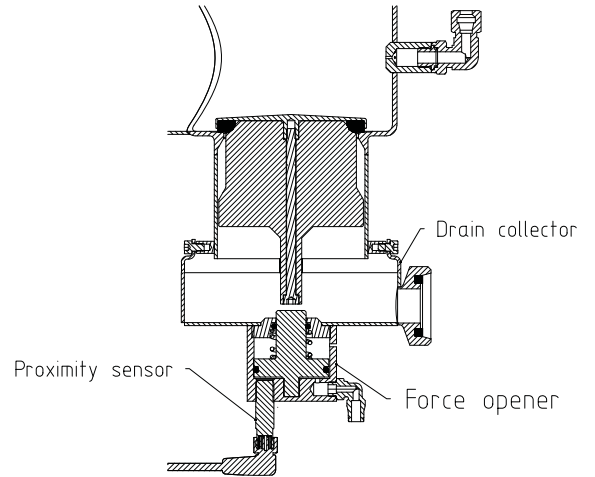

Volumetric Flow Capacity

Medium: Air

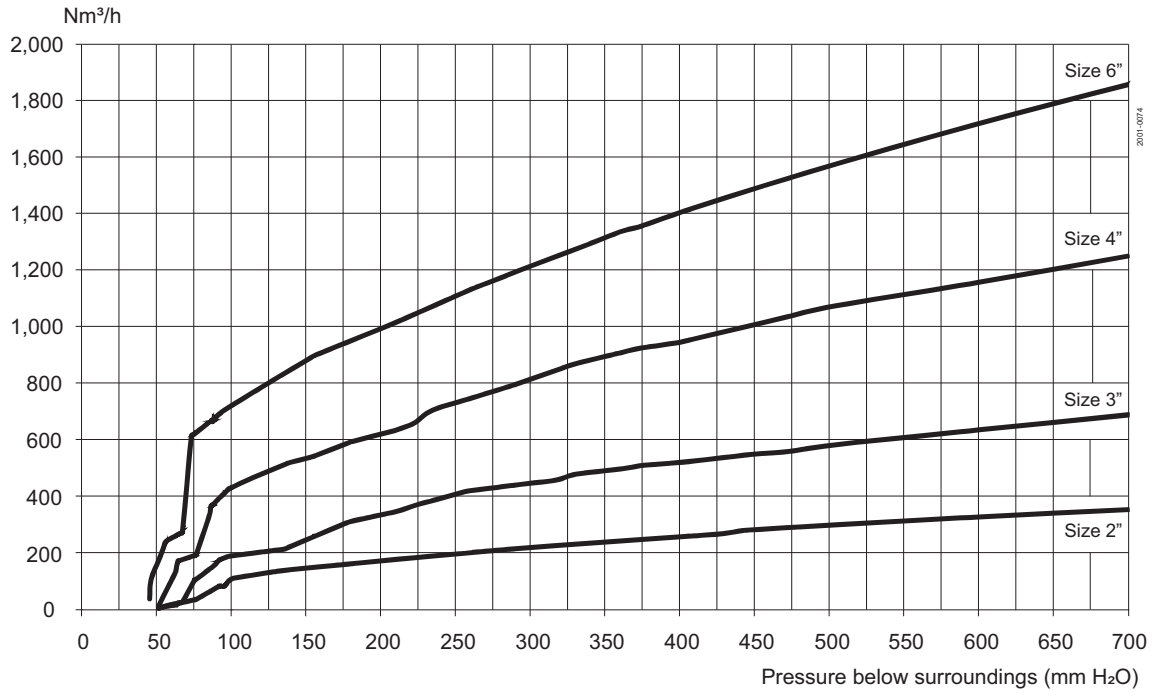

Alfa Laval reserves the right to change specifications without prior notification.

How to contact Alfa Laval

Contact details for all countries
are continually updated on our website.
Please visit www.alfalaval.com to
access the information direct.