



Alfa Laval SB Pressure Exhaust Valve

Regulating valves

Introduction

The Alfa Laval SB Pressure Exhaust Valve is a pneumatic regulating valve that automatically releases pressure in a hygienic process tank when it exceeds the set pressure. To ensure safe pressure regulations at all times, the set pressure can easily be adjusted manually or from a remote location that is connected to the central control system.

Application

This pneumatic regulating valve is designed for use in process tanks or vessels for hygienic applications in the brewery, food, dairy, beverage and many other industries.

Benefits

- Reliable control of tank top pressure
- Easy to integrate with SCANDI BREW® safety valves and top plates
- Fully cleanable with Cleaning-in-Place system
- Easy to integrate into existing installations
- Low investment due to simplified installation

Standard design

The Alfa Laval SB Pressure Exhaust Valve consists of an AISI 316L stainless steel body, EPDM seals, and fittings for 4/6 mm nylon air hoses for set pressure and force opening. A cleaning nozzle and closing plug for the Cleaning-in-Place (CIP) inlet are also supplied. An optional pneumatic cleaning nozzle is available to replace the closing plug.

The valve can be mounted directly on top of the tank or vessel, as part of a SCANDI BREW® tank top system, or elsewhere along the pipework as long as there is proper drainage from the valve housing.

Working principle

The Alfa Laval SB Pressure Exhaust Valve is operated by means of the set pressure being applied to the top of a membrane set. The pressure regulation will be identical to the set point pressure. The set pressure is either reduced to the required pressure by means of a manual precision regulator or an IP converter controlled by a programmable logic controller (PLC). When the tank pressure exceeds the set pressure, the valve will open and release pressure through the valve side branch for atmospheric discharge or collection. To ensure correct working conditions, there should be no pressure buildup after the vent port.

Air pressure exerted on the lower portion of the membrane set forces the SB Pressure Exhaust Valve open. The valve is now fully cleanable either by an optional CIP supply valve, supplying CIP to the cleaning nozzle on the valve housing, or cleaning along with rest of the installation with a separate CIP line.



TECHNICAL DATA

Size (diameter)	Size (diameter)
38mm	1-4 bar
51mm	0,5-4 bar

PHYSICAL DATA

Materials	
Product wetted steel parts:	EN 1.4404 (AISI 316L)
Product wetted seals:	EPDM
Product wetted polymers:	Polypropelen

Connection

Weld End acc. ISO 2037

Unions DIN 11851

Cleaning In Place (CIP)

After force-opening of the Pressure Exhaust Valve by an air signal to the lower part of the membrane set, the valve is fully cleanable either by means of an optional CIP supply valve to the cleaning nozzle on the valve housing or simultaneously in line with cleaning of vent/recovery mains.

Dimensions (mm)

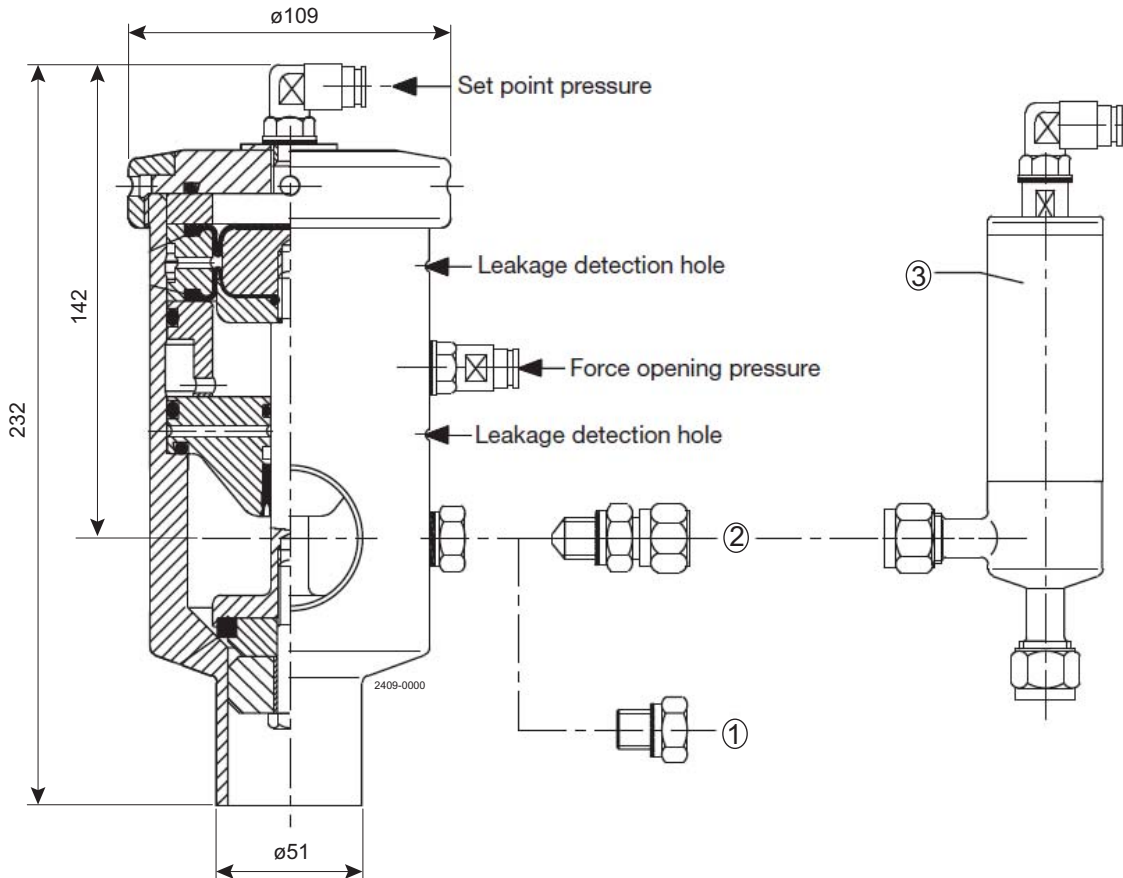

Pos. 1: Cleaning nozzle

Pos. 2: Closing plug

Pos. 3: Pneumatic CIP supply valve

Pos. 1 and 2 included in valve

Alfa Laval reserves the right to change specifications without prior notification.

How to contact Alfa Laval

Contact details for all countries are continually updated on our website. Please visit www.alfalaval.com to access the information direct.