



# Alfa Laval Unique DV-ST UltraPure

## Diaphragm valves

### Introduction

The Alfa Laval Unique DV-ST UltraPure Diaphragm Valve is an aseptic diaphragm valve used to shut off, divert and/or regulate the flow of fluids through hygienic, high-purity and aseptic processing lines.

### Application

This diaphragm valve is designed for use in dosing, filling, diverting and regulating duties in hygienic, high-purity and aseptic processes in the biotech and pharmaceutical industries as well as aseptic and hygienic processes in the dairy, food, beverage and brewery industries.

### Benefits

- Versatile, modular and durable design
- Compact, reliable and straightforward
- Hygienic and aseptic design
- Easy installation, validation and qualification
- Standard with full Q-doc documentation meeting the demands from high-purity applications
- Meets current Good Manufacturing Practice (cGMP) regulations

### Standard design

The Alfa Laval Unique DV-ST UltraPure diaphragm valve has a modular design that consists of a valve body, diaphragm, and either a handle for manual operation or an actuator for pneumatic operation. It can be designed to suit any application.

The actuator is standard in Stainless steel execution and available in two versions. A HighPressure version (SS/HP) and a Slim (SS/SL) version for std. duties. Both versions are available in either Normally Closed (NC), Normally Open (NO) or an Air/Air (A/A) activated solution. Furthermore also ATEX compliant and autoclaveable.

The DV-ST UltraPure diaphragm valve can be fitted with sensing and control units from an extensive range. Options include control units that suit AS-Interface, IO-Link and digital operating platforms.

The diaphragms are available as soft elastomer (EPDM) as well as hard elastomers (PTFE/EPDM and TFM/EPDM).

Alfa Laval DV-ST UltraPure valve bodies are available in cast, forged, and block options to suit the most demanding applications. A choice of surface finishes and connection types are also available. For critical applications with corrosive media, special alloys such as Hastelloy, duplex, and AL-6XN materials in block design are available upon request.



### Working principle

The Alfa Laval Unique DV-ST UltraPure Diaphragm Valve has two modes of operation: manual operation by means of a handle and pneumatic operation by means of a pneumatic actuator.

For manual operation, a simple turn of the handle lifts the compressor upwards, moving the diaphragm away from the weir of the valve body thereby opening the valve. Turning the handle in the opposite direction pushes the compressor downwards onto the diaphragm, pressing the diaphragm against the weir of the valve body, thereby closing the valve.

For pneumatic operation, the pneumatic actuator controls the axial movement of a piston, thereby opening or closing the valve depending on the actuator function.

## Valve Body Design

The valve bodies are available in a wide variety of valve types and configuration options (dimension standards, connections, surface finish and material).

- 2-way body
- T-body (Zero dead-leg design)
- Tank outlet body
- Tandem body / IAV solutions
- Multi-port body

Configurator available.



2-way



T-Block



Multi-port



Tandem



Tank outlet-block

## PHYSICAL DATA

### Materials

Body types	Cast CF3M (316L)	Forged 1.4435 (316L)	Block* 1.4435 (316L)
2-way	✓	✓	✓
T			✓
Tank outlet			✓
Tandem / IAV solutions	✓	✓	✓
Multi-port			✓

\* Other alloys on request.

	Cast	Forged and block
Material	CF3M (316L)	1.4435 (316L)
Delta ferrite	< 5.0%	< 0.5%
Sulphur content	0.005%-0.017%	0.005-0.017%
Internal surface finish	Ra < 0.51 µm Ra < 0.38 µm EP <sup>1)</sup>	Ra < 0.51 µm Ra < 0.38 µm EP <sup>1)</sup>
External surface finish	Blasted	Blasted <sup>2)</sup>

<sup>1)</sup> Electro Polished

<sup>2)</sup> Block with external machined surface.

0.51µm = SF1, 0.38 µm = SF4

### Sensing and control units:

A wide range of sensing and control units are available for actuators consisting of:

- Controls unit
- Indication units
- ATEX units
- Stroke limiters - Only for SS/SL Slim actuators

### Unique DV-ST SS/HP HighPressure version actuator DN8-15 (1/4"-1/2")

Adapter for mounting of ThinkTop V50, ThinkTop Basic, ThinkTop D30 and IndiTop - see automation accessories

### Unique DV-ST SS/SL Slim version actuator

All sizes require adaptor for mounting of Sensing & Control solutions - see automation accessories

## Documentation

All UltraPure valves are delivered with our comprehensive Q-Doc documentation package, which includes:

- 3.1/ MTR traceability certificate corresponding to EN 10204
- FDA - Declaration of conformity to FDA (CFR 21: 177.2600 or 177.1550)
- USP - Certificate of conformity to USP Class VI (Chapter 88, biological reactivity test)
- TSE/ADI - Declaration (Transmissible Spongiform Encephalopathy/Animal Derived Ingredients)
- Cure date of diaphragms
- Surface finish conformity declaration

The following documentation is available upon request:

- Surface finish certificate (Ra test results)
- ATEX certificate

## Handle and actuator:

The diaphragm valves can be operated by a handle or a pneumatic actuator. Alfa Laval offers 2 different types of manual handles and 1 type of pneumatic actuator.

### Actuator



Model	SS/SL	SS/HP
Sizes		DN 8 - 100 1/4" - 4"
Housing		Stainless steel
Intermediate part		Stainless steel
Compressor, stem		Stainless steel
Full Vacuum		✓
Leakage Detection		✓
Autoclavable 1)		✓
Max. Air Temperature		80°C
Max. Air Pressure 2)		7 bar
Stroke limiter	Yes	No
OD Surface	Polished	Blasted
ATEX,		✓
	II 2G Ex h IIB T4 Gb (-10°C ≤ tamb ≤ 80°C)	
	II 3D Ex h IIIB T100°C Dc (-10°C ≤ tamb ≤ 80°C)	
Max working pressure	Delta P 100% (3)	Delta P 0% (3)
Sizes	1/4" - 1 1/2" EPDM 10 bar PTFE/EPDM 6 bar TFM/EPDM 6 bar	Sizes 1/4" - 4" EPDM 10 bar PTFE/EPDM 10 bar TFM/EPDM 6 bar
	2"-4" EPDM 8 bar PTFE/EPDM 5 bar TFM/EPDM 5 bar	

1) 121°C for max. 60 min

2) Min. Air pressure see instruction manual

3) See image below for Delta P 100% and Delta P 0%

Delta P 100%

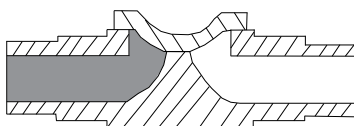

Delta P 0%

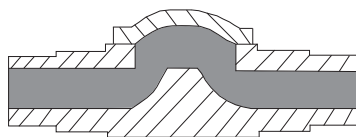

## Handles



Model	SS/SS	C/SS
Size	DN 8 - 100 1/4" - 4"	DN 8 - 100 1/4" - 4"
Handwheel	Stainless steel	PA <sup>1)</sup>
Bonnet	Stainless steel	Stainless steel
Spindle + compressor <sup>1)</sup>	Stainless steel	Stainless steel
Max. product pressure	10 bar	10 bar
Overclosure protection	✓	✓
Optical positioner	✓	✓
Autoclavable	✓ <sup>2)</sup>	✓ <sup>2)</sup>
Leakage Detection	✓	✓

<sup>1)</sup> PA (polyamid)

<sup>2)</sup> 121 °C for max. 60 min.

## Diaphragms



The diaphragms are available as soft elastomer (EPDM) as well as hard elastomers (PTFE/EPDM and TFM/EPDM).

The hard elastomers are supported by a soft elastomer (EPDM). The 2-piece design allows the two elastomers to work independently of each other, thereby reducing tension caused by different thermal properties.

Diaphragms are available with 3 different types of connections: thread, bayonet and button connection.

- Threaded connections are used on soft elastomers  $\geq$  DN 25 (1")
- Bayonet connections are used on all hard elastomer  $\geq$  DN 15 (1/2")
- Button connections are used on all small sizes.

### Material selection:

Each application has different working conditions and therefore different demands on the diaphragm. In order to select the most suitable diaphragm for your application, the following factors should be considered:

- Working pressure
- Application temperatures
- Process fluids (product, cleaning liquid, sterilisation, passivation, etc.)

Soft elastomer (EPDM) is suitable for most applications and for high working temperatures. Including continuous steam application.

Hard elastomers offer the highest possible degree of chemical resistance. Our TFM (PTFE grade) elastomer is a more flexible material and has some of the features of soft elastomer including for example low creep.

For further information, please see below or contact Alfa Laval for further guidance.

Diaphragm properties:

Description	Temperature recommendations °C			Documentation			Available sizes	Available Diaphragm connections:		
	Min.	Max.	Max. Steam	FDA	USP	TSE		Button <sup>3)</sup>	Thread	Bayonet <sup>4)</sup>
EPDM	-40°C	130°C	150°C <sup>1)</sup>	✓	✓	✓	DN 8 - 100	DN 8 - 20	DN 25 - 100	
PTFE/EPDM	-5°C	175°C	150°C <sup>2)</sup>	✓	✓	✓	DN 15 - 100		DN 15 - 100	
TFM/EPDM	-5°C	175°C	150°C <sup>2)</sup>	✓	✓	✓	DN 8 - 100	DN 8 - 10	DN 15 - 100	

- 1) Continuous temperature
- 2) 40 min. steam sterilisation
- 3) < DN25 thread optional
- 4) TFM/EPDM point-fixed thread optional

FDA - Declaration of conformity to FDA (CFR 21: 177.2600 or 177.1550)

USP - Certificate of conformity to USP Class VI (chapter 88, biological reactivity test)

TSE/ADI Declaration (Transmissible Spongiform Encephalopathy /Animal Derived Ingredients)

Alfa Laval Cast valve bodies with Optimized Flow utilize smaller diaphragm and topwork vs. Valve pipe dimension. Topwork being either pneumatic or manual. This giving the benefit of having a Slim and light weight valve.

Correct spare parts are easy to identify via the diaphragm tab, stating the giving size of diaphragm and topwork to be used on the valve. See image below

Alfa Laval EPDM Diaphragm



Alfa Laval PTFE/EPDM

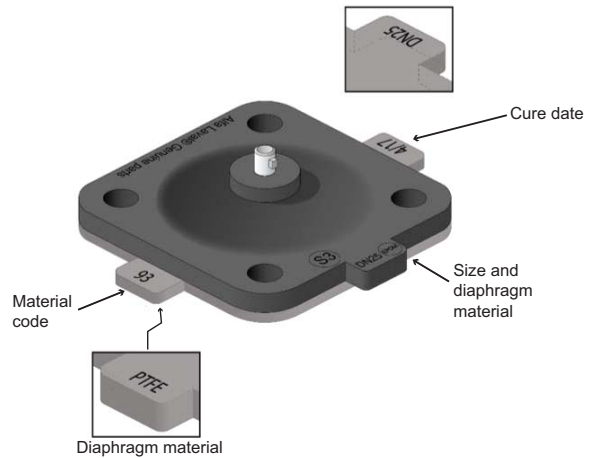

Pressure drop/capacity table

Kv value (Pipe standard ISO 1127 / DIN/A), Forged and Block

kv in m <sup>3</sup> /h Δp = 1 bar								
DN 8-10 (1/4"-3/8")	DN 15 (1/2")	DN 20 (3/4")	DN 25 (1")	DN 40 (1½")	DN 50 (2")	DN 65 (2½")	DN 80 (3")	DN 100 (4")
1.6	4.2	8.8	13.1	41.0	69.4	94.3	152.0	204.9

Kv value (Pipe standard ASME BPE), Forged and Block

kv in m <sup>3</sup> /h Δp = 1 bar								
DN 8-10 (1/4"-3/8")	DN 15 (1/2")	DN 20 (3/4")	DN 25 (1")	DN 40 (1½")	DN 50 (2")	DN 65 (2½")	DN 80 (3")	DN 100 (4")
0.20	2.2	4.8	9.5	23.9	46.5	69.7	111.7	200.0

KV Value Cast bodies Optimized Flow (OP)

KV Value (Pipe standard ASME BPE / ISO 2037 Cast OP)

kv in m <sup>3</sup> /h Δp = 1 bar							
DN8-10	DN15	DN20	DN25	DN40	DN50	DN65	DN80
1/4"-3/8"	1/2"	3/4"	1"	1½"	2"	2½"	3"
0.2	2.2	5.1	10.8	25.3	53.4	79.7	128.6

KV values are based on lab test

Drain angle x:

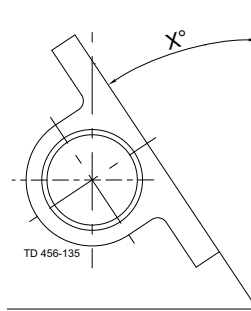

Drain angles, forged and block valve bodies

Port size DN	Inch	ASME BPE	ISO 2037	DIN11850 (Series A)	ISO 1127 (Series B)
8	1/4"	42°	27°	32°	26°
10	3/8"	33°	25°	35°	28°
15	1/2"	35°	26°	24°	20°
20	3/4"	34°	30°	28°	23°
25	1"	29°	29°	25°	21°
32	1 1/4"	-	-	18°	26°
40	1 1/2"	30°	29°	27°	22°
50	2"	25°	24°	24°	20°
65	2 1/2"	23°	23°	20°	16°
80	3"	26°	27°	23°	22°
100	4"	14°	14°	13°	8°

Drain angles, forged mini valve bodies

Port size DN	Inch	ASME
8	1/4"	38°
10	3/8"	30°
15	1/2"	26°

Drain angles, Cast OP valve bodies

Port size DN	Inch	ASME	ISO 2037
15	1/2"	26.5°	7°
20	3/4"	20°	14°
25	1"	22.7°	22°
40	1 1/2"	13.8°	13°
50	2"	16.1°	15°
65	2 1/2"	14.7°	15°
80	3"	14.9°	15°

## Dimensions (mm)

### 2-way body:

2-way bodies are the standard configuration for shut off and regulating functions.

The 2-way bodies are available from forged or cast material.

The cast bodies feature a unique Optimized Flow design (OP) providing optimization on diaphragm and topworks being applied on the valve.

See further in the DV-ST catalogue

### Weld ends: (mm)

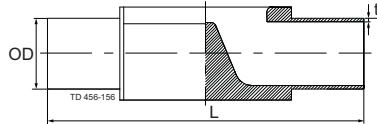

Port size		Length	ASME BPE	ISO 2037	DIN11850 <sup>1)</sup> (Series A)	ISO1127 <sup>1)</sup> (Series B)
DN	Inch	L	OD x t	OD x t	OD x t	OD x t
8	¼"	89	6.35 x 0.89	12.00 x 1.00	10.00 x 1.00	13.50 x 1.60
10	⅜"	89	9.53 x 0.89	12.70 x 1.00	13.00 x 1.50	17.20 x 1.60
15	½"	89	12.70 x 1.65			
15	½"	110	12.70 x 1.65	17.20 x 1.00	19.00 x 1.50	21.30 x 1.60
20	¾"	119	19.05 x 1.65	21.30 x 1.00	23.00 x 1.50	26.90 x 1.60
25	1"	129	25.40 x 1.65	25.00 x 1.20	29.00 x 1.50	33.70 x 2.00
32	1¼"	129	-	-	35.00 x 1.50	
32	1¼"	161	-	-	-	42.40 x 2.00
40	1½"	161	38.10 x 1.65	38.00 x 1.20	41.00 x 1.50	48.30 x 2.00
50	2"	192	50.80 x 1.65	51.00 x 1.20	53.00 x 1.50	60.30 x 2.00
65	2½"	218	63.50 x 1.65	63.50 x 1.60	70.00 x 2.00	76.10 x 2.00
80	3"	256	76.20 x 1.65	76.10 x 1.60	85.00 x 2.00	88.90 x 2.30
100	4"	218	101.60 x 2.11	101.60 x 2.00	104.00 x 2.00	114.30 x 2.30

<sup>1)</sup> Forged only

Build-in length of weld/clamp valve bodies: Weld ends L/2 + CL ends L/2 = total length of valve body.

### Clamp ends: (mm)

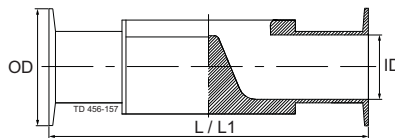

Port size		Length	Length	Clamp ASME BPE		Clamp ISO 2852		Clamp DIN 32676 <sup>1)</sup>		Clamp DIN 32676 <sup>1)</sup>	
DN	Inch	L <sup>3)</sup>	L <sup>12)</sup>	for ASME BPE		for ISO 2037		for Series A/DIN		for Series B/ISO	
				OD	ID	OD	ID	OD	ID	OD	ID
8	¼"	89	63.5	25.00	4.57	34.00	10.00	25.00	8.00	25.0	10.3
10	⅜"	89	63.5	25.00	7.75	34.00	10.70	34.00	10.00		
15	½"	-	63.5	25.00	9.40						
10	⅜"	108								25.0	14.0
15	½"	108	89	25.00	9.40	34.00	15.20	34.00	16.00	50.5	18.1
20	¾"	118	102	25.00	15.75	34.00	19.30	34.00	20.00	50.5	23.7
25	1"	127	114	50.50	22.10	50.50	22.60	50.50	26.00	50.5	29.7
32	1¼"	127						50.50	32.00		
32	1¼"	159								64.0	38.4
40	1½"	159	140	50.50	34.80	50.50	35.60	50.50	38.00	64.0	44.3
50	2"	191	159	64.00	47.50	64.00	48.60	64.00	50.00	77.5	56.3 <sup>1)</sup>
65	2½"	216	194	77.50	60.20	77.50	60.30	91.00	66.00	91.0	72.1
80	3"	254	222	91.00	72.90	91.00	72.90	106.00	81.00	106.0	84.3
100	4"	305	-	118.92	97.38	119.00	97.60	119.00	100.00	119.00	109.7

<sup>1)</sup> Forged only

<sup>2)</sup> ASME BPE forged valves only, short version acc. to ASME BPE dimension table for hygienic clamp joint: Weir style diaphragm valve

<sup>3)</sup> Standard build-in length acc. EN 558-1, Series 7

Build-in length of weld/clamp valve bodies: Weld ends L/2 + CL ends L/2 = total length of valve body.

Other sizes and connections available on request.



**T- body:**

T are constructed with weir as close as possible to the internal contour of the main tube thereby minimising potential dead leg. The T- bodies are available as machined from block. T valve can furthermore be made with steam or sample port solutions. See further in the DV-ST catalogue.



**Dimension table for T-block bodies - ASME**

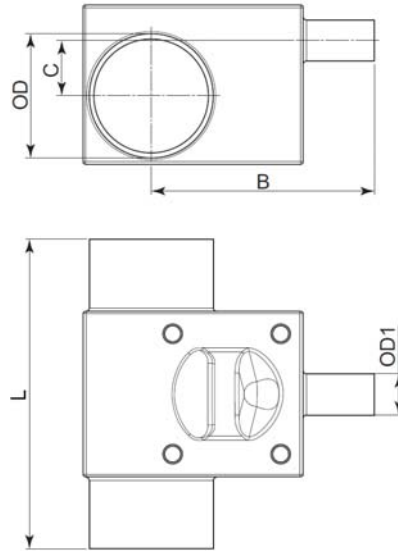

Main tube DN	Valve DN	Main tube OD x t mm	Valve OD1 x t mm	B - Weld mm	B - Clamp mm	C mm	L - Weld mm	L - Clamp mm
8	8	ø6.35x0.89	ø6.35x0.89	34.9	47.6	0.0	57.0	82.4
10	8	ø9.53x0.89	ø6.35x0.89	35.6	48.3	3.2	57.0	82.4
15	8	ø12.7x1.65	ø6.35x0.89	37.0	49.7	4.6	81.0	106.4
20	8	ø19.05x1.65	ø6.35x0.89	39.9	52.6	9.0	81.0	106.4
25	8	ø25.4x1.65	ø6.35x0.89	43.2	55.9	12.3	81.0	106.4
40	8	ø38.1x1.65	ø6.35x0.89	55.4	68.1	13.0	81.0	106.4
50	8	ø50.8x1.65	ø6.35x0.89	57.7	70.4	19.4	81.0	106.4
65	8	ø63.5x1.65	ø6.35x0.89	63.5	76.2	25.8	81.0	106.4
80	8	ø76.2x1.65	ø6.35x0.89	70.2	88.9	32.1	81.0	106.4
10	10	ø9.53x0.89	ø9.53x0.89	35.6	48.3	3.2	57.0	82.4
15	10	ø12.7x1.65	ø9.53x0.89	37.0	49.7	4.6	81.0	106.4
20	10	ø19.05x1.65	ø9.53x0.89	39.9	52.6	9.0	81.0	106.4
25	10	ø25.4x1.65	ø9.53x0.89	43.2	55.9	12.3	81.0	106.4
40	10	ø38.1x1.65	ø9.53x0.89	55.4	68.1	13.0	81.0	106.4
50	10	ø50.8x1.65	ø9.53x0.89	57.7	70.4	19.4	81.0	106.4
65	10	ø63.5x1.65	ø9.53x0.89	69.5	76.2	25.8	81.0	106.4
80	10	ø76.2x1.65	ø9.53x0.89	70.2	82.9	32.1	81.0	106.4
15	15	ø12.7x1.65	ø12.7x1.65	57.7	70.4	3.6	95.0	120.4
20	15	ø19.05x1.65	ø12.7x1.65	58.6	71.3	8.0	95.0	120.4
25	15	ø25.4x1.65	ø12.7x1.65	62.0	74.7	11.3	95.0	120.4
40	15	ø38.1x1.65	ø12.7x1.65	68.6	81.3	16.95	95.0	120.4
50	15	ø50.8x1.65	ø12.7x1.65	75.2	87.9	20.6	95.0	120.4
65	15	ø63.5x1.65	ø12.7x1.65	81.8	94.5	24.75	95.0	120.4
80	15	ø76.2x1.65	ø12.7x1.65	88.3	101.0	29.1	95.0	120.4
20	20	ø19.05x1.65	ø19.05x1.65	64.9	77.6	1.0	109.0	134.4
25	20	ø25.4x1.65	ø19.05x1.65	68.4	81.1	6.3	109.0	134.4
40	20	ø38.1x1.65	ø19.05x1.65	75.1	87.8	13.0	109.0	134.4
50	20	ø50.8x1.65	ø19.05x1.65	81.7	94.4	17.6	109.0	134.4
65	20	ø63.5x1.65	ø19.05x1.65	88.2	100.9	21.2	109.0	134.4
80	20	ø76.2x1.65	ø19.05x1.65	94.8	107.5	24.9	109.0	134.4
25	25	ø25.4x1.65	ø25.4x1.65	72.9	85.6	4.3	117.0	142.4
40	25	ø38.1x1.65	ø25.4x1.65	79.6	92.3	12.4	117.0	142.4
50	25	ø50.8x1.65	ø25.4x1.65	85.3	98.0	18.1	117.0	142.4
65	25	ø63.5x1.65	ø25.4x1.65	91.9	104.6	22.2	117.0	142.4
80	25	ø76.2x1.65	ø25.4x1.65	98.4	111.1	25.9	117.0	142.4
40	40	ø38.1x1.65	ø38.1x1.65	88.9	101.6	2.4	143.0	168.4
50	40	ø50.8x1.65	ø38.1x1.65	95.8	108.5	11.3	143.0	168.4
65	40	ø63.5x1.65	ø38.1x1.65	102.4	115.1	17.6	143.0	168.4
80	40	ø76.2x1.65	ø38.1x1.65	109.1	121.8	22.6	143.0	168.4
50	50	ø50.8x1.65	ø50.8x1.65	111.5	124.2	4.6	170.0	195.4
65	50	ø63.5x1.65	ø50.8x1.65	111.7	124.4	12.8	170.0	195.4
80	50	ø76.2x1.65	ø50.8x1.65	118.4	131.1	18.9	170.0	195.4
65	65	ø63.5x1.65	ø63.5x1.65	134.4	147.1	12.7	190.0	215.4
80	65	ø76.2x1.65	ø63.5x1.65	134.5	147.2	12.9	190.0	215.4
80	80	ø76.2x1.65	ø76.2x1.65	152.1	164.8	9.9	233.0	258.4

Note: Contact Alfa Laval for 4" T-block valves

T-block valves are available in all dimension standards (ASME, DIN, ISO2037, ISO1127) Hybrid solutions with mixed dimension standards (ASME, DIN, ISO2037, ISO1127) is furthermore possible, please contact Alfa Laval".

**Tank outlet body:**

Tank outlet bodies with minimised dead leg and complete drainability.

The tank outlet valve bodies are available as machined from block. Tank outlet valves can furthermore be supplied with steam or sample port. See further in the DV-ST catalogue



Dimension table for Tank outlet-block bodies - all standards

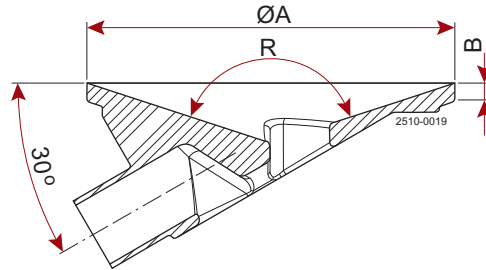

DN	ØA (mm)	B (mm)	R
DN15 (1/2")	90	5.4	144°
DN20 (3/4")	100	5.4	144°
DN25 (1")	120	5.4	144°
DN40 (1½")	150	5.4	144°
DN50 (2")	180	5.4	144°
DN65 (2½")	200	5.4	144°
DN80 (3")	250	5.4	144°

For OD dimensions see two-way valves.

Note: Contact Alfa Laval for 4" T-block valves

**Tandem body:**

Tandem solutions are available in a wide variety of angles and positions for sampling, steam, condensate drain or divert function. Tandem solutions can be made in a welded two valve construction or as an Integral Access Valves block solution (IAV). See further in the DV-ST catalogue



**Tandem body configuration**

To configure the tandem body the position and the angle of the two bodies are selected by combining one of the letters with one of the numbers in the following overview.

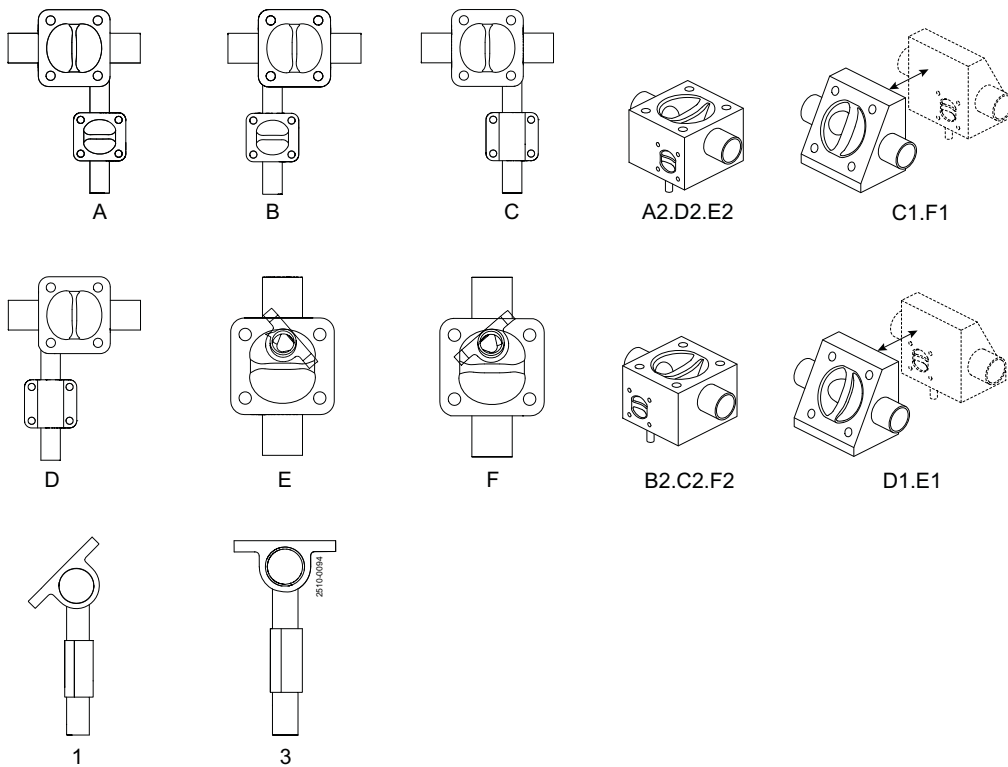

**Multi-port body:**

Multi-port bodies are a space and time saving alternative to valve clusters minimising dead volumes. Alfa Laval offers customised solutions for both simple and complex processes.



For more details, please contact Alfa Laval.





Alfa Laval reserves the right to change specifications without prior notification.

---

**How to contact Alfa Laval**

Contact details for all countries are continually updated on our website. Please visit [www.alfalaval.com](http://www.alfalaval.com) to access the information direct.