



Alfa Laval Unique SSV ATEX

Single seat valves

Introduction

The Alfa Laval Unique SSV ATEX Standard is a versatile, reliable pneumatic single seat valve with a single contact surface between the plug and the seat to minimize the risk of contamination. Its compact, modular and hygienic design meets the highest process demands in terms of hygiene and safety.

Built on the well-proven Unique SSV platform, it is ATEX-certified for use in environments with an explosive atmosphere. Few moving parts ensure high reliability and low maintenance costs. A wide range of optional features enables customization to specific process requirements.

Application

The Unique SSV ATEX Standard is designed for safe, uninterrupted production in environments with an explosive atmosphere across the dairy, food, beverage, brewery and many other industries.

Benefits

- Supremely reliable and versatile
- Cost effective and modular design
- Extremely strong and durable
- Protection against leakage and bacterial contamination
- Certified for use by 3-A, hygienic standards and ATEX

Standard design

The Alfa Laval Unique SSV ATEX range is available in a one-, two- or three-body configuration, with easy-to-configure valve bodies, plug, sealing, actuator and clamp rings. The valve can be configured as a shutoff valve with two to four working ports or as a changeover valve with up to six ports.

To ensure flexibility, the valve seat that sits between the two bodies in the changeover version is provided for assembly. The valve seals are optimized for durability and long service life through a defined compression design. The actuator is connected to the valve body using a yoke, and all components are assembled with clamp rings.

Using the Alfa Laval Anytime configurator, it is easy to customize to meet virtually any process requirement.

Working principle

The Alfa Laval Unique SSV ATEX Standard is a hygienic pneumatic single seat valve that is remotely operated by means of compressed air. The actuator smooths operation and protects process lines against pressure peaks. The valve can be controlled using an Alfa Laval ThinkTop® Basic Intrinsically Safe.

Certificates

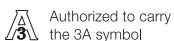

TECHNICAL DATA

Temperature	
Temperature range:	-10°C to +135°C (EPDM)
Ambient temperature:	10°C to +40°C

Pressure	
Max. product pressure:	1000 kPa (10 bar)
Min. product pressure:	Full vacuum
Air pressure, actuator:	500 to 700 kPa (5 to 7 bar)

ATEX	
Classification:	II 2 G D c T4*

*This equipment is outside the scope of the directive 2014/34/EU and must not carry a separate CE marking according to the directive as the equipment has no own ignition source

Valve Body Combinations

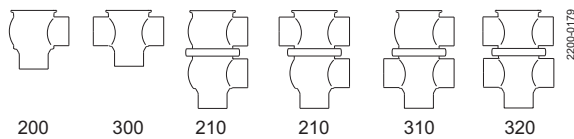

Actuator function

- Pneumatic downward movement, spring return.
- Pneumatic upward movement, spring return.
- Pneumatic upward and downward movement A/A.

PHYSICAL DATA

Materials - valve/actuator	
Product wetted steel parts:	1.4404 (316L)
Other steel parts:	1.4301 (304)
External surface finish:	Semi-bright (blasted)
Internal surface finish:	Bright (polished), Ra < 0.8 µm
Product wetted seals:	EPDM
Other seals:	NBR
Actuator stem:	PAGG PAGI/GT, MH, 14-250, CF40
Spring:	Coated steel

Options

- A. Male parts or clamp liners in accordance with required standard.
- B. Control and Indication: ThinkTop Basic Intrinsically Safe.
- C. Product wetted seals in HNBR or FPM (Note! Temperature range 10°C to +135°C for ATEX Versions).
- D. Plug seals in HNBR or FPM (Note! Temperature range 10°C to +135°C for ATEX Versions).
- E. External surface finish bright.

Note!

For further details, see instruction manual ESE00674.

Other valves in the same basic design

The Unique SSV valve range includes several purpose built valves. Below are some of the valve models available, though please use the Alfa Laval Anytime configurator for full access to all models and options.

- Reverse acting valve.
- Tank Outlet valve.
- Tangential valve.

Semi-Maintainable actuator comes with 5 year warranty.

Dimensions (mm)

Nominal size	Inch tubes						DIN tubes					
	DN/OD						DN					
	25	38	51	63.5	76.1	101.6	25	40	50	65	80	100
A _{1 1)}	313	314	363	389	422	467	315	315	365	389	427	470
A _{2 1)}	328	334	388	414	452	497	330	335	390	414	457	500
A _{3 1)}	360*	374	436	475	521	591	367*	379	440.6	481	534	596
A _{4 1)}	372*	391	458	497	548	618	379*	396	463	503	561	623
C	47.8	60.8	73.8	86.3	98.9	123.6	52	64	76	92	107	126
OD	25	38	51	63.5	76.1	101.6	29	41	53	70	85	104
ID	21.8	34.8	47.8	60.3	72.9	97.6	26	38	50	66	81	100
t	1.6	1.6	1.6	1.6	1.6	2	1.5	1.5	1.5	2	2	2
E	50	49.5	61	81	86	119	50	49.5	62	78	87	120
F ₁	15	20	25	25	30	30	15	20	25	25	30	30
F ₂	12*	17	22	22	27	27	12*	17	22	22	27	27
H	85	85	ø115	ø115	ø155	ø155	85	85	ø115	ø115	ø155	ø155
H (high pressure)	85	ø115	ø155	ø155	ø155	ø155	85	ø115	ø155	ø155	ø155	ø155
M (ISO clamp)	21	21	21	21	21	21	-	-	-	-	-	-
M (DIN clamp)	-	-	-	-	-	-	21	21	21	28	28	28
M (DIN male)	-	-	-	-	-	-	22	22	23	25	25	30
M (SMS male)	20	20	20	24	24	35	-	-	-	-	-	-
Weight (kg)												
Shut-off valve	3.1	3.3	5.5	6.5	11.3	13.6	3.2	3.4	5.5	6.6	11.8	13.6
Change-over valve	3.9	4.2	7.1	8.5	14	18	4.1	4.5	7.2	8.8	14.9	17.9

* = only available with replaceable elastomer plug seal.

1) For exact A₁ - A₄ dimensions, please refer to information in Anytime configurator.

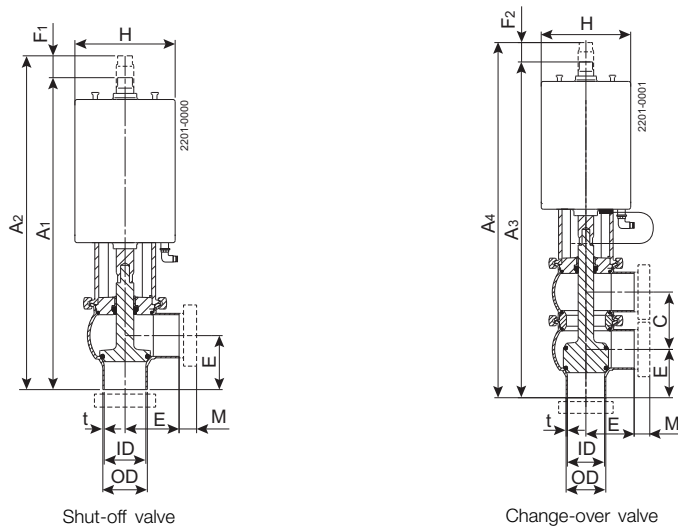

Please Note!

Opening/closing time will be effected by the following:

- The air supply (air pressure).
- The length and dimensions of the air hoses.
- Number of valves connected to the same air hose.
- Use of single solenoid valve for serial connected air actuator functions.
- Product pressure.

Air Connections Compressed air:

R 1/8" (BSP), internal thread.

Size	Air consumption (litres free air) for one stroke		
	DN25-40	DN50-65	DN80100
	DN/OD 25-38 mm	DN/OD 51-63.5 mm	DN/OD 76.1-101.6 mm
NO and NC	0.2 x air pressure [bar]	0.5 x air pressure [bar]	1.3 x air pressure [bar]
A/A	0.5 x air pressure [bar]	1.1 x air pressure [bar]	2.7 x air pressure [bar]

Pressure drop/capacity diagrams

Change-over Valves

ΔP (kPa)

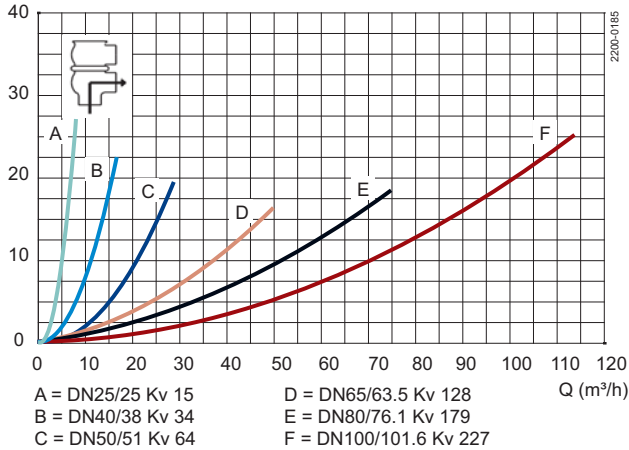

Change-over Valves

ΔP (kPa)

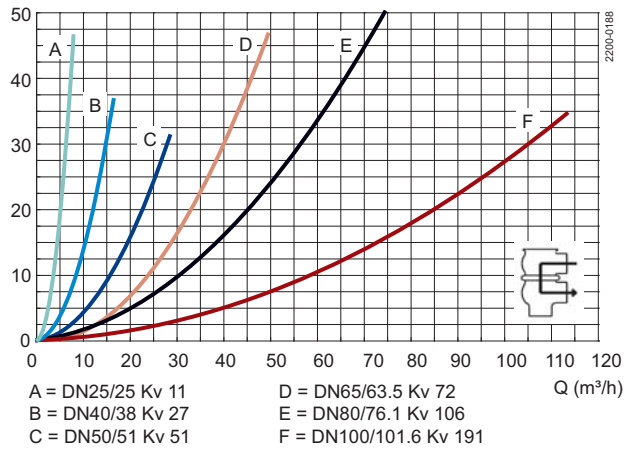

ΔP (kPa)

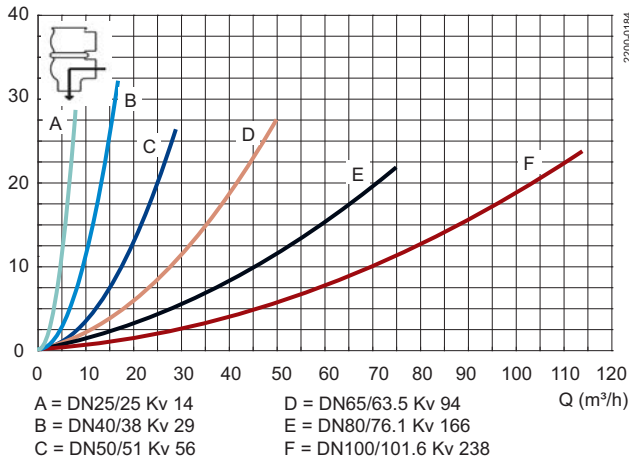

Shut-off Valves

ΔP (kPa)

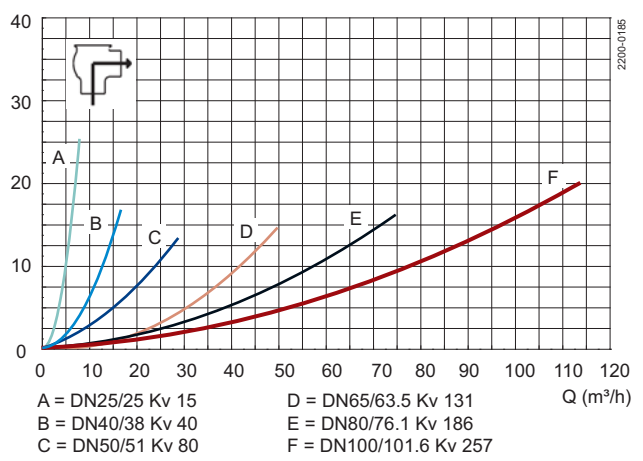

ΔP (kPa)

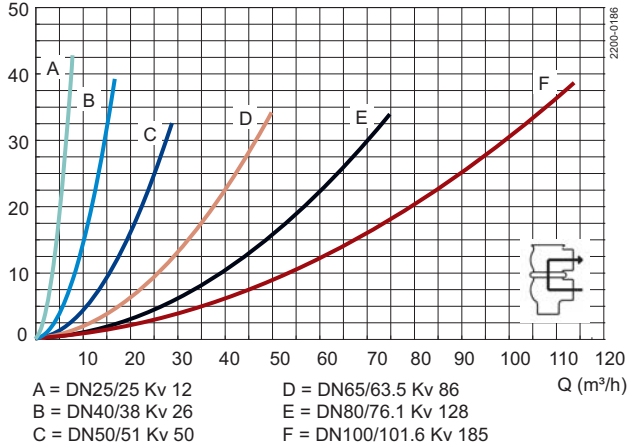

ΔP (kPa)

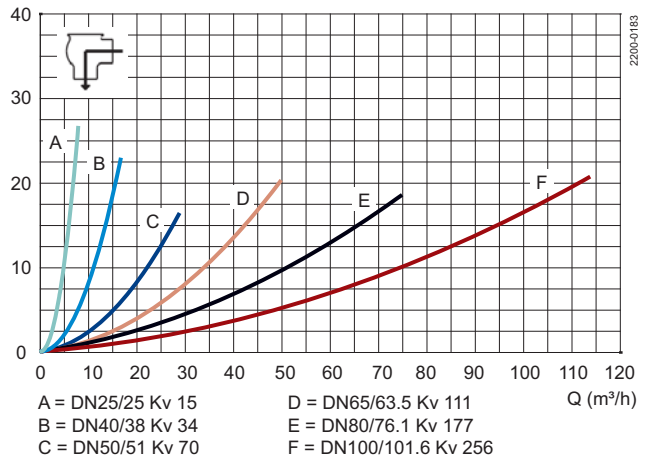

Note!

For the diagrams the following applies:

Medium: Water (20°C)

Measurement: In accordance with VDI2173

Pressure drop can also be calculated in Anytime configurator

Pressure drop can also be calculated with the following formula:

$$Q = Kv \times \sqrt{\Delta p}$$

Where

Q = Flow in m³/h.

Kv = m³/h at a pressure drop of 1 bar (see table above).

Δp = Pressure drop in bar over the valve.

How to calculate the pressure drop for an ISO 2.5" shut-off valve if the flow is 40 m³/h
2.5" shut-off valve, where Kv = 111 (See table above).

$$Q = K_v \times \sqrt{\Delta p}$$

$$40 = 111 \times \sqrt{\Delta p}$$

$$\Delta p = \left(\frac{40}{111}\right)^2 = 0.13 \text{ bar}$$

(This is approx. the same pressure drop by reading the y-axis above)

Pressure data for Unique Single Seat ATEX Valve

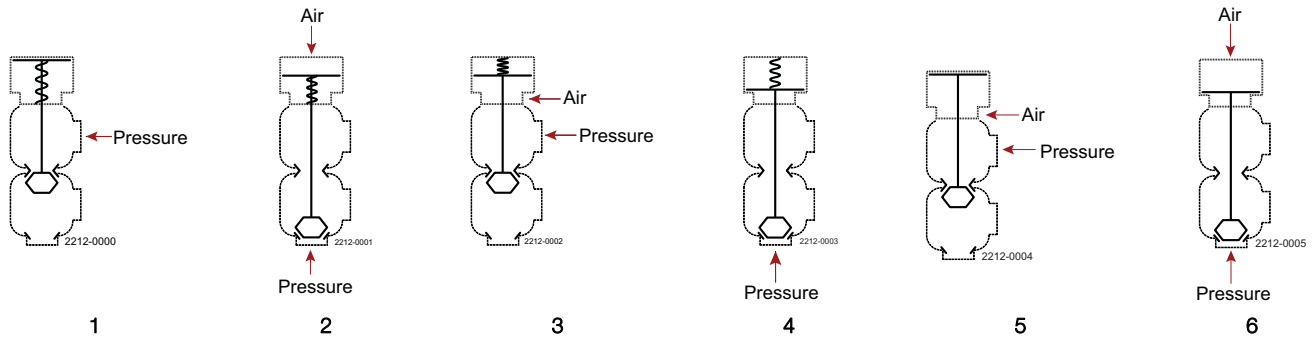

Table 1 - Shut-off and Change-over valves Max. pressure in bar without leakage at the valve seat

Actuator / Valve body combination and direction of pressure	Air pressure (bar)	Plug position	Valve size					
			DN 25 DN/OD	DN 40 DN/OD	DN50 DN/OD	DN 65 DN/OD	DN 80 DN/OD	DN 100 DN/OD
			25 mm	38 mm	51 mm	63.5 mm	76.1 mm	101.6 mm
1	5	NO	10.0	8.2	8.4	4.5	6.8	4.4
	6		9.2	4.4	5.9	3.4	4.4	2.9
2	6	NO	10.0	7.6	9.6	5.6	7.2	4.8
	7		10.0	10.0	10.0	7.8	10.0	6.7
3	5	NC	10.0	5.7	6.8	3.7	4.7	3.0
	6		10.0	9.8	10.0	6.1	7.7	5.0
4	7	NC	10.0	10.0	10.0	8.5	10.0	6.9
	5		10.0	6.3	7.2	4.2	6.4	4.2
5	5	A/A	10.0	10.0	10.0	10.0	10.0	9.4
	6		10.0	10.0	10.0	10.0	10.0	10.0
6	7	A/A	10.0	10.0	10.0	10.0	10.0	10.0
	5		10.0	10.0	10.0	10.0	10.0	9.1
6	6	A/A	10.0	10.0	10.0	10.0	10.0	10.0
	7		10.0	10.0	10.0	10.0	10.0	10.0

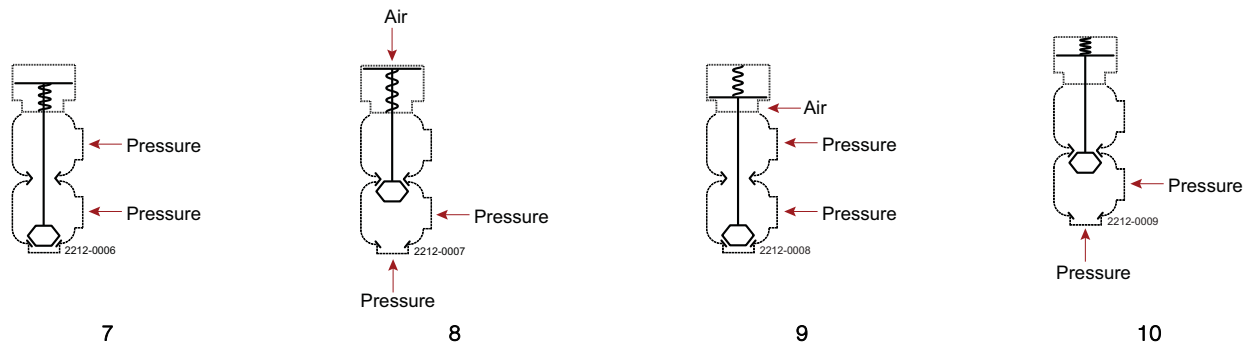

Table 2 - Shut-off and Change-over valves Max. pressure in bar against which the valve can open

Actuator / Valve body combination and direction of pressure	Air pressure (bar)	Plug position	Valve size					
			DN 25 DN/OD	DN 40 DN/OD	DN50 DN/OD	DN 65 DN/OD	DN 80 DN/OD	DN 100 DN/OD
			25 mm	38 mm	51 mm	63.5 mm	76.1 mm	101.6 mm
7	5	NO	10.0	10.0	10.0	7.4	9.7	6.3
	6		10.0	7.8	10.0	6.1	7.1	4.7
8	6	NO	10.0	10.0	10.0	8.3	9.9	6.6
	7		10.0	10.0	10.0	10.0	10.0	8.5
9	5	NC	10.0	10.0	6.8	6.6	7.5	4.9
	6		10.0	10.0	10.0	9.0	10.0	6.9
10	7	NC	10.0	10.0	10.0	10.0	10.0	8.8
	5		10.0	9.7	10.0	6.8	9.1	6.1

Alfa Laval reserves the right to change specifications without prior notification.

How to contact Alfa Laval

Contact details for all countries are continually updated on our website. Please visit www.alfalaval.com to access the information direct.